

Coburn Prima 2-4

Face Fixed Door Closer

Prima | Face Fixed Door Closers
Coburn Product Data Sheet



Features

- High strength die cast aluminium body
- Adjustable closing and latching speeds
- All weather finish for working temperature 55°C to - 42°C
- Adjustable Closing Force: Size 2-4
- Standard regular arm and top frame installation
- Parallel arm bracket for parallel arm installation (optional)
- Available with hold open (optional)
- Rack and pinion mechanism
- Non-handed: suitable for left and right hand opening doors
- Back check available as an option
- CE Marked (0359-CPR-00727)

*The stated maximum door width is for standard installation.
In the case of unusually high doors or where the door is located in a draughty or windy position a larger power size of door closer should be used.

Technical Specifications

- Door Weight: 20 - 80kg
- Closing Force: Size 2-4
- Dimensions: 220mm x 50mm x 44mm
- BS EN 1154 Classification 482-4114

Connect with



Face Fixed Door Closer

TECHNICAL SPECIFICATION

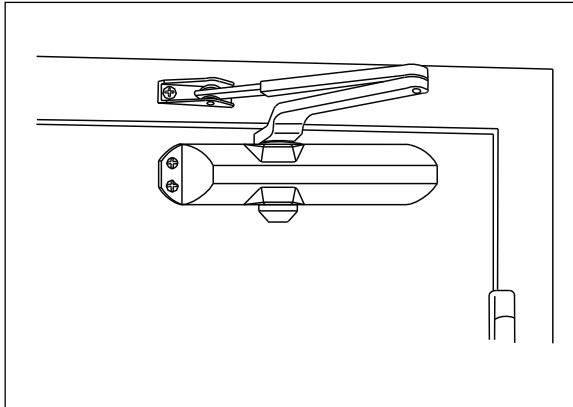

Regular Arm Fixing (Fig. 1)

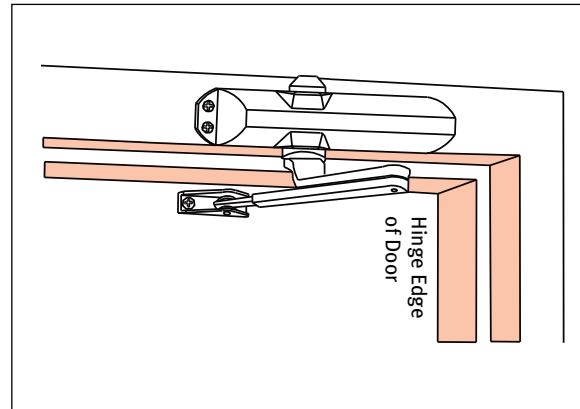

Top Frame Fixing (Fig. 2)

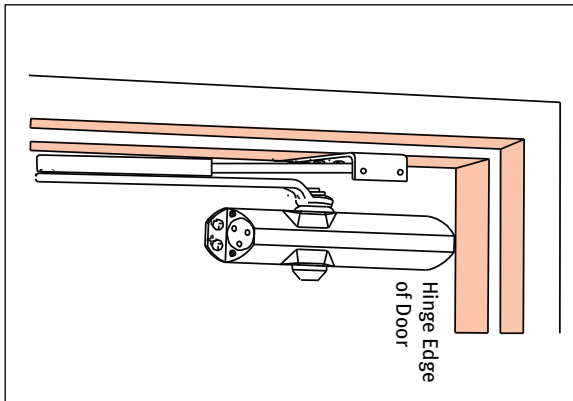

Parallel Arm Fixing (Fig. 3)

- A: Body Length: 220mm
- B: Horizontal Hole Spacing: 202mm
- C: Vertical Hole Spacing: 19mm
- D: Body Height: 50mm
- E: Body Projection: 44mm
- F: Arm Shoe Spacing: 45mm

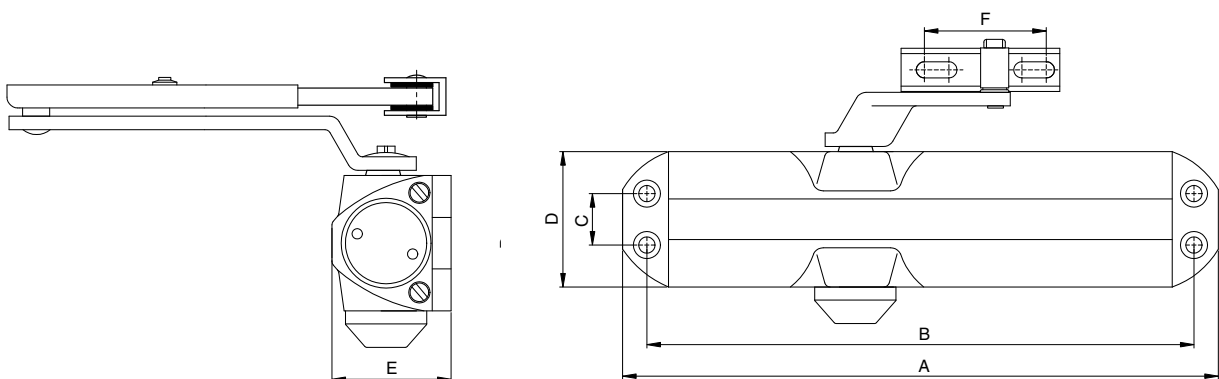

For further information on Coburn products and services:

Coburn Sliding Systems India PTE Ltd
27 Weston Street, Room No 302,
3rd Floor, Kolkata – 700012. India
Tel: 91 33 46011916 - 40084842
sales@coburn.in
www.coburn.in

Coburn Sliding Systems Ltd
Unit 1 Cardinal West, Cardinal Way,
Cardinal Distribution Park,
Godmanchester, Huntingdon,
Cambridgeshire. PE29 2XN
United Kingdom
Tel: +44 (0)20 8545 6680
sales@coburn.co.uk
www.coburn.co.uk

Dealer Stamp